

Dehler  **38 SQ**





A TRUE DEHLER – SPEED MEETS QUALITY

_ SINCE 1963, Dehler has been developing sailing yachts that epitomise performance cruising and the power of innovation. This continuous quest for excellence has resulted in yet another leap forward. It is a yacht that carries the founding principles in its very name: the Dehler 38SQ.

PROCEED WITH SPEED – SMART PERFECTION – GERMAN ENGINEERING

Dehler  **38 SQ**

DETAILS MAKE THE DIFFERENCE

State of the art performance cruiser. With smart new developments, the Dehler 38SQ scores in all areas: comfort, quality and performance. For an enhanced sailing experience from the first to the last moment.



◁ The yacht's sharp, distinctive lines reflect her progressive design and impressive dynamics.

Choose high-performance squaretop sails to increase efficiency and reduce heel.



▷ Additional windows in the coach-roof bring in lots of natural light.

▷ The fixed bowsprit with built-in anchor arm puts the tack point for a gennaker or Dehler Freeride even further forward.



▷ Retractable footrests, flush-mounted into the cockpit sole, allow an especially comfortable footing on the heel.





STIRRING PERFORMANCE TURBO CHARGED

Take on the sporting challenge. Give your Dehler 385Q that extra bit of dynamism and trim the yacht for maximum sailing performance. Select carbon rigging, squaretop membrane sails, extended bowsprit and racing winches.



EFFORTLESS CRUISING. LAID-BACK MOOD.

_ Let the sea breeze carry you. The wind and the Dehler 385Q do all the work for you. Sheets and halyards run directly to the helm, putting everything within reach. Sail handling becomes truly relaxing.





ON THE HOOK IN THE LAP OF LUXURY

Once you have reached your anchorage, the Dehler 385Q will continue to inspire you. The cockpit offers plenty of space to relax – and the perfect atmosphere at any time. The full teak decking is enhanced with an all-round LED light strip for ambient lighting.





Let your soul take a holiday. The bathing platform with handrail and flush-mounted bathing ladder is the perfect place for it. Celebrate the end of an unforgettable day on the large, comfortable cockpit benches.



SUPREME COMFORT. FLAWLESSLY FINISHED.

— **A cockpit for sailing enthusiasts.** Everything is just so: from sports steering wheels with Y-spokes to the flush-mounted traveller. The entire cockpit is on a single level, with free access to the bathing platform. The cockpit coaming flows smoothly into the rounded instrument consoles, which noticeably lengthen the benches.



EVERY LINE WORKS IN HARMONY

— Magnetic attraction from every angle. Cleaner lines. A sportier look. More striking hull windows - and a bowsprit perfectly integrated into the deckline. The newly designed coachroof now offers an extra saloon window on each side.





CLASS TAKES MANY FORMS. HERE ARE THREE.

STANDARD

MAST HEIGHT ABOVE WL
17.70m / 58'1"

MAINSAIL
43.00m² / 463sq ft

JIB (105 %)
35.60m² / 383sq ft

TOTAL SAIL AREA
78.60m² / 846sq ft

RIG

Standard
I 15.07m / 49'5"
J 4.36m / 14'4"
P 14.50m / 47'7"
E 5.20m / 17'1"

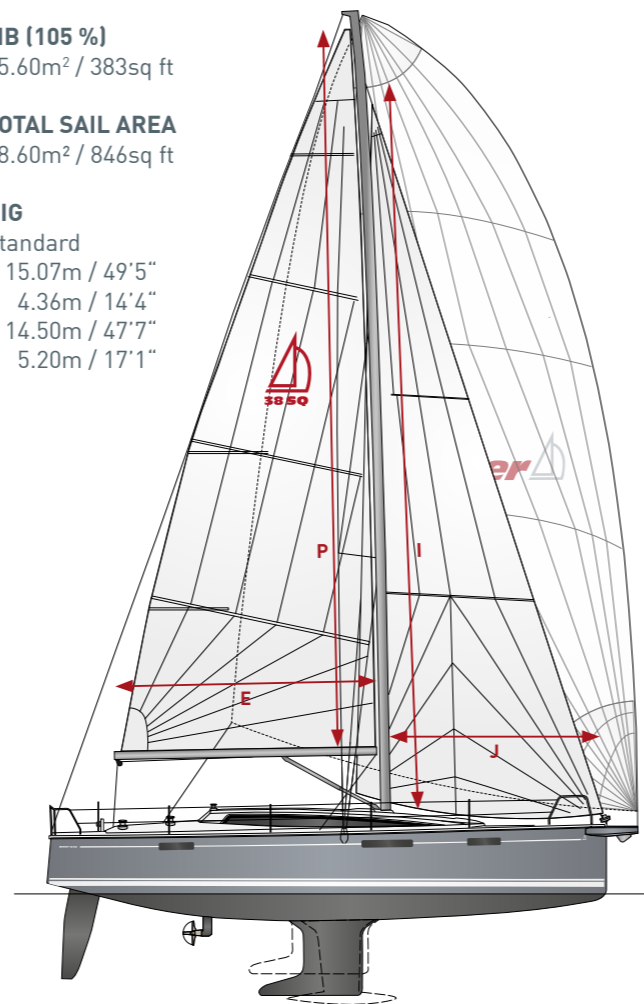

COMPETITION ALU

MAST HEIGHT ABOVE WL
17.70m / 58'1"

MAINSAIL
48.00m² / 517sq ft

JIB (105 %)
35.60m² / 383sq ft

TOTAL SAIL AREA
83.60m² / 900sq ft

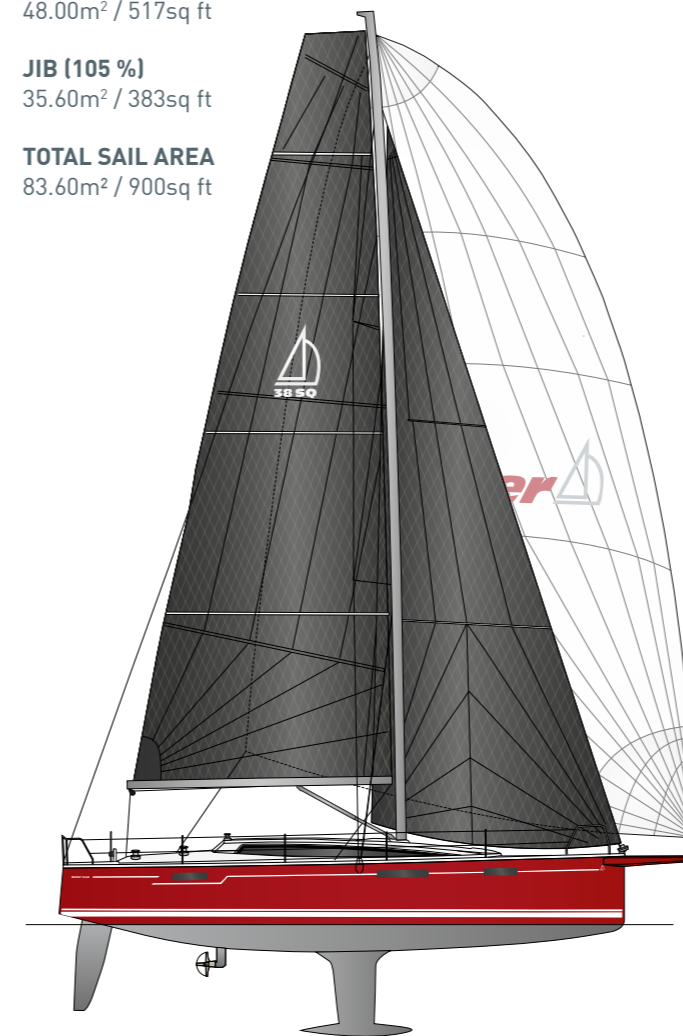

COMPETITION CARBON

MAST HEIGHT ABOVE WL
17.80m / 58'5"

MAINSAIL
49.00m² / 527sq ft

JIB (105 %)
35.60m² / 383sq ft

TOTAL SAIL AREA
84.60m² / 911sq ft



HULL

LOA 12.07m / 39'7"
Hull length 11.30m / 37'1"
LWL 10.40m / 34'1"
Beam 3.75m / 12'4"

DRAUGHT

Standard 2.03m / 6'8"
Competition 2.24m / 7'5"
Shallow 1.60m / 5'3"

DISPLACEMENT

Standard 7.50t / 16,534lbs
Competition 7.00t / 15,432lbs
Shallow 7.60t / 16,755lbs

BALLAST

Standard 2.38t / 5,247lbs
Competition 2.05t / 4,508lbs
Shallow 2.75t / 6,062lbs

ENGINE

Diesel 29PS / hp

TANKS

Fresh water 295l / 77.93gal
Fuel tank 160l / 42.27gal

HULL DESIGN

judel / vrolijk & co

CE CERTIFICATE

A - 6 / B - 10

SPINNAKER

competition 101.70m² / 1,095sq ft

GENNAKER

standard 103.70m² / 1,116sq ft
competition 121.00m² / 1,302sq ft

DEHLER FREERIDE

82.10m² / 884sq ft



AN AMBIENCE SHAPED BY ELEGANCE

— A homage to light. Brightness characterises the noble interior of the Dehler 38SQ. Every surface contributes to the friendly, sunny atmosphere. One design element in particular is lavishly exploited: natural light. Noticeably larger windows in the saloon and cabins make you forget you are below deck.



Dehler  **38 SQ**



SUPERB FABRICS NATURALLY ILLUMINATED

Coherent interior design. Off-white walls perfectly match any upholstery fabric. Handrails in black add an effective highlight. The double-leaf saloon table connects both sofas – or, when folded, leaves the way to the forward cabin free.

The first-class collection of upholstery has been carefully matched to the interior design.



oyster



cliffside

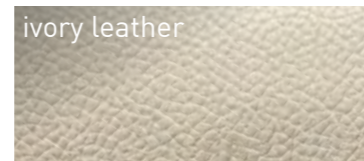

ivory leather

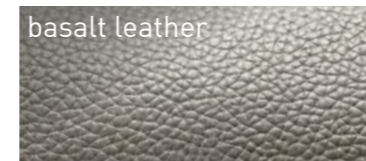

basalt leather



teak

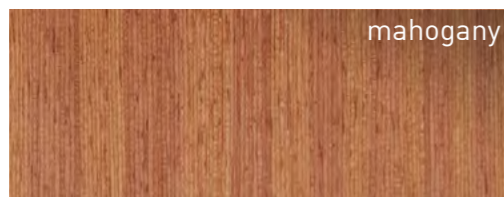

mahogany



oak

Fine furniture woods are used extensively. Each variation features its special, characteristic grain.



TIME FOR GREAT CUISINE

— **Enjoyment with all the trimmings.** A refrigerator with top and side access, a pull-out wine rack in the saloon table: the living area is full of smart details. There is enough storage space for all your crew's culinary desires.



PURE LUXURY BATHED IN LIGHT

Exquisite fittings. Larger hull windows bring natural light into the owner's cabin. Clever indirect lighting adds the finishing touches. The large designer bathroom with separate shower area also owes its charm to this use of light.

CABIN LAYOUT | STANDARD

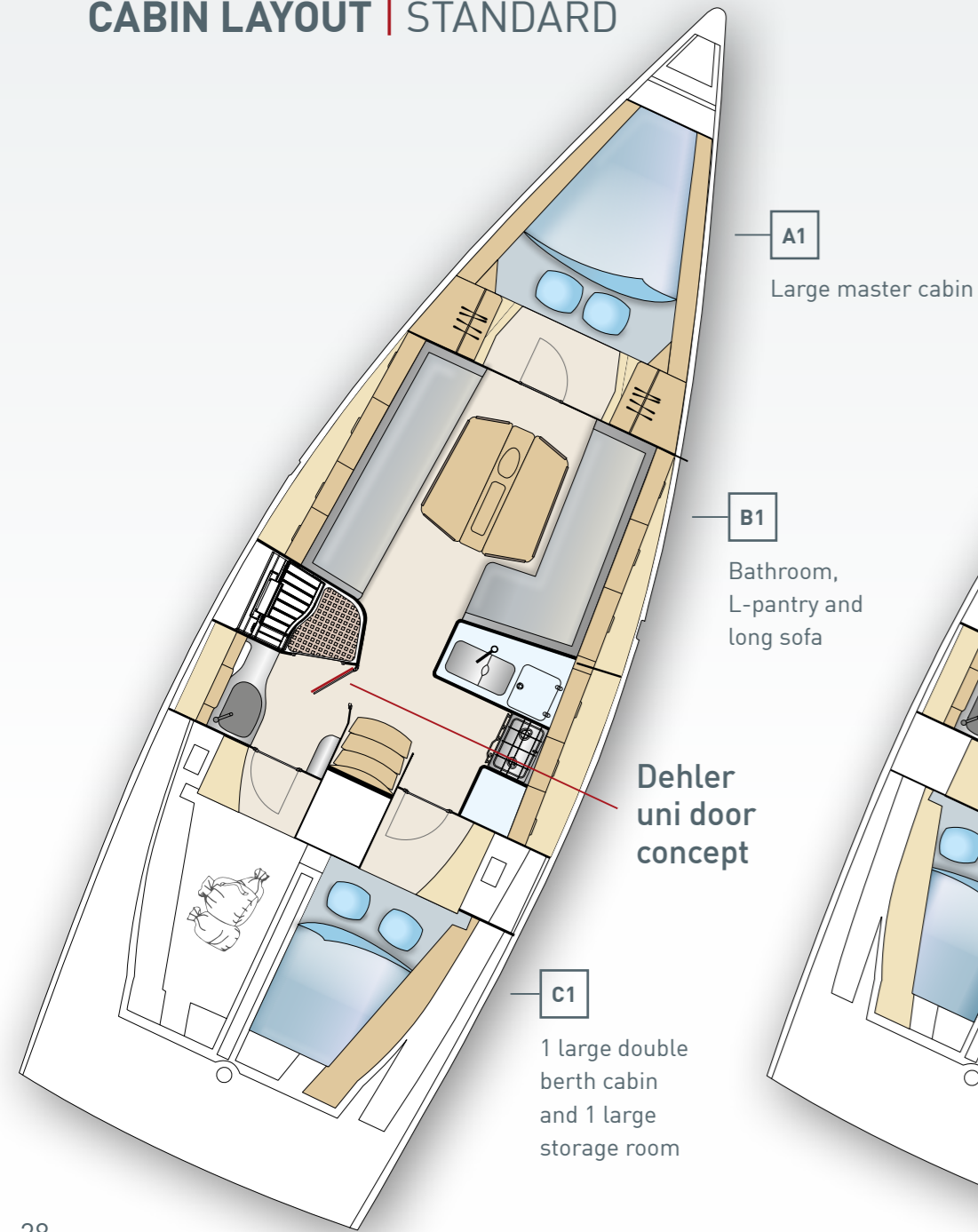

| OPTION

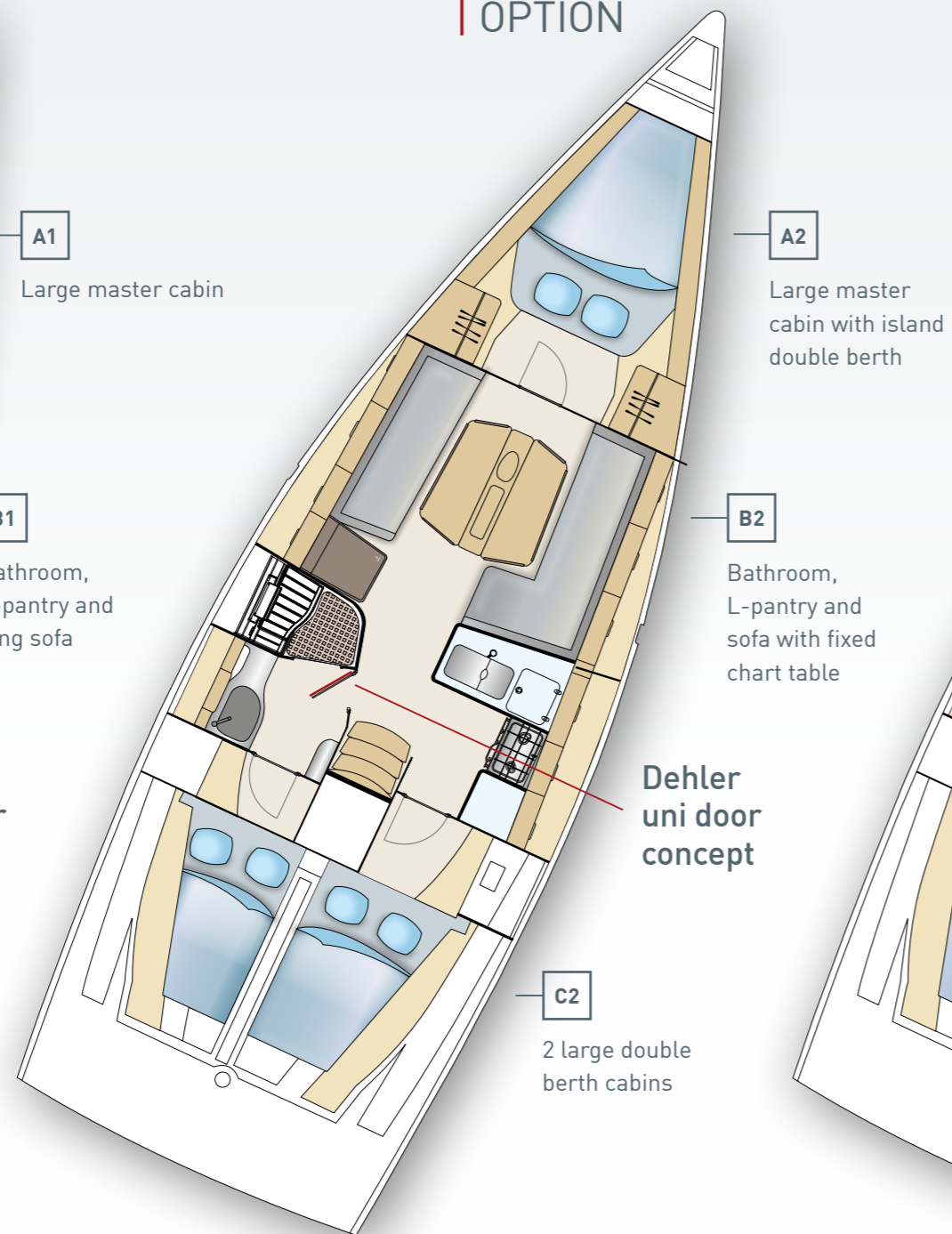

| OPTION

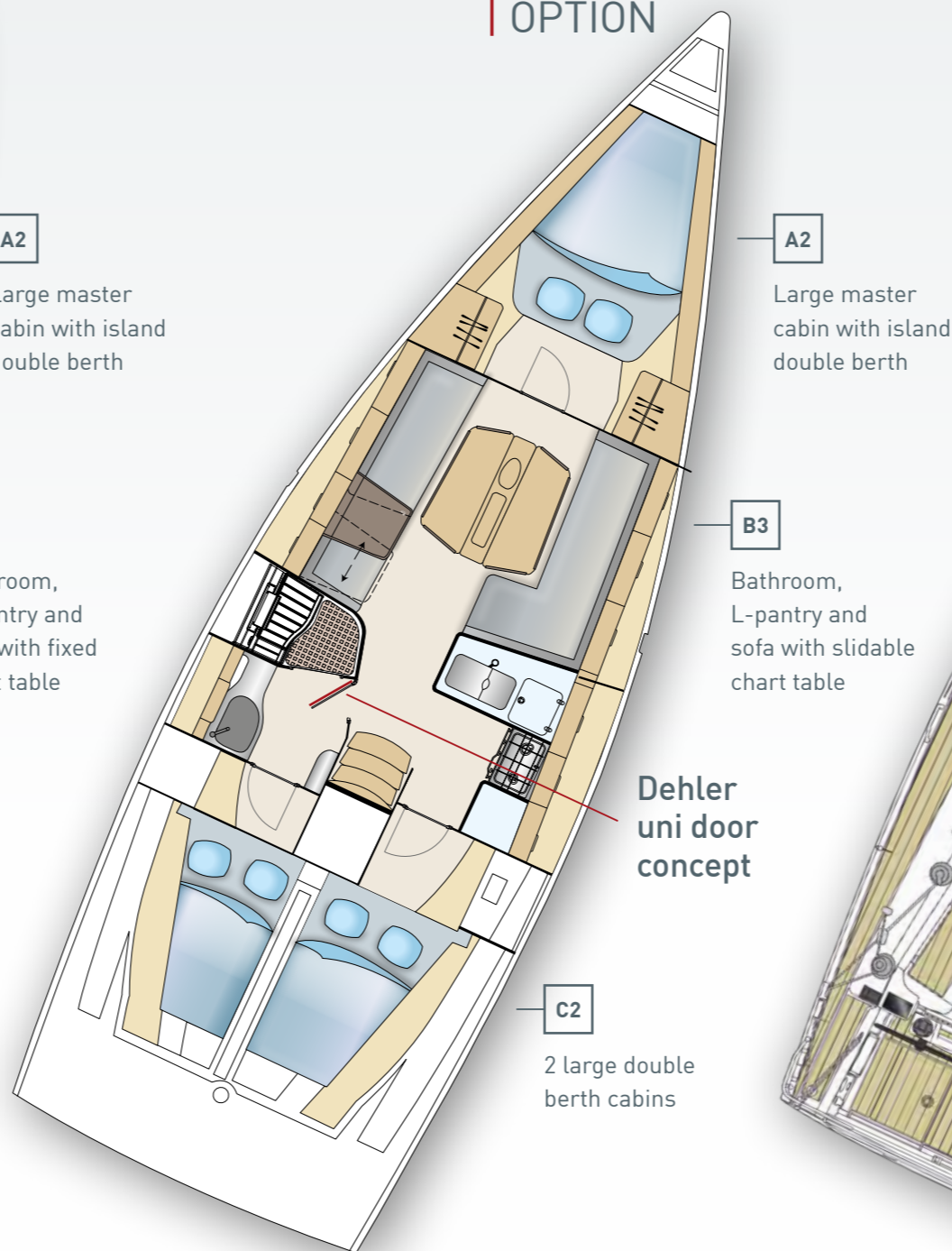

DECK LAYOUT

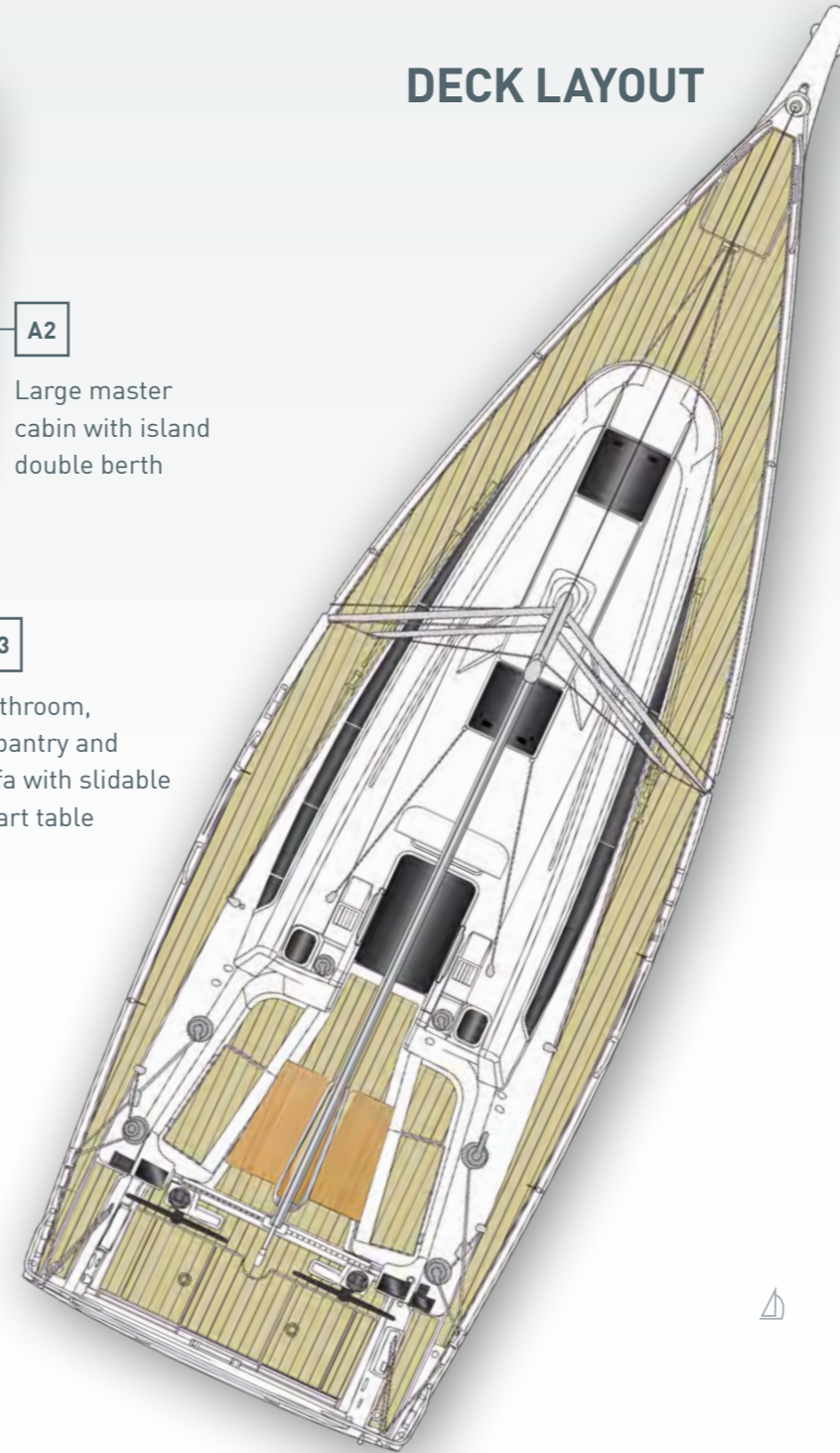

LAYOUT FOR YOUR LIFESTYLE

Tailored to your lifestyle. A navigation table in the saloon, an island bed for the owners or a second cabin aft for your guests: your way of life decides.





Dehler  **38 SQ**

ADVANCED ENGINEERING. IN EVERY DETAIL.

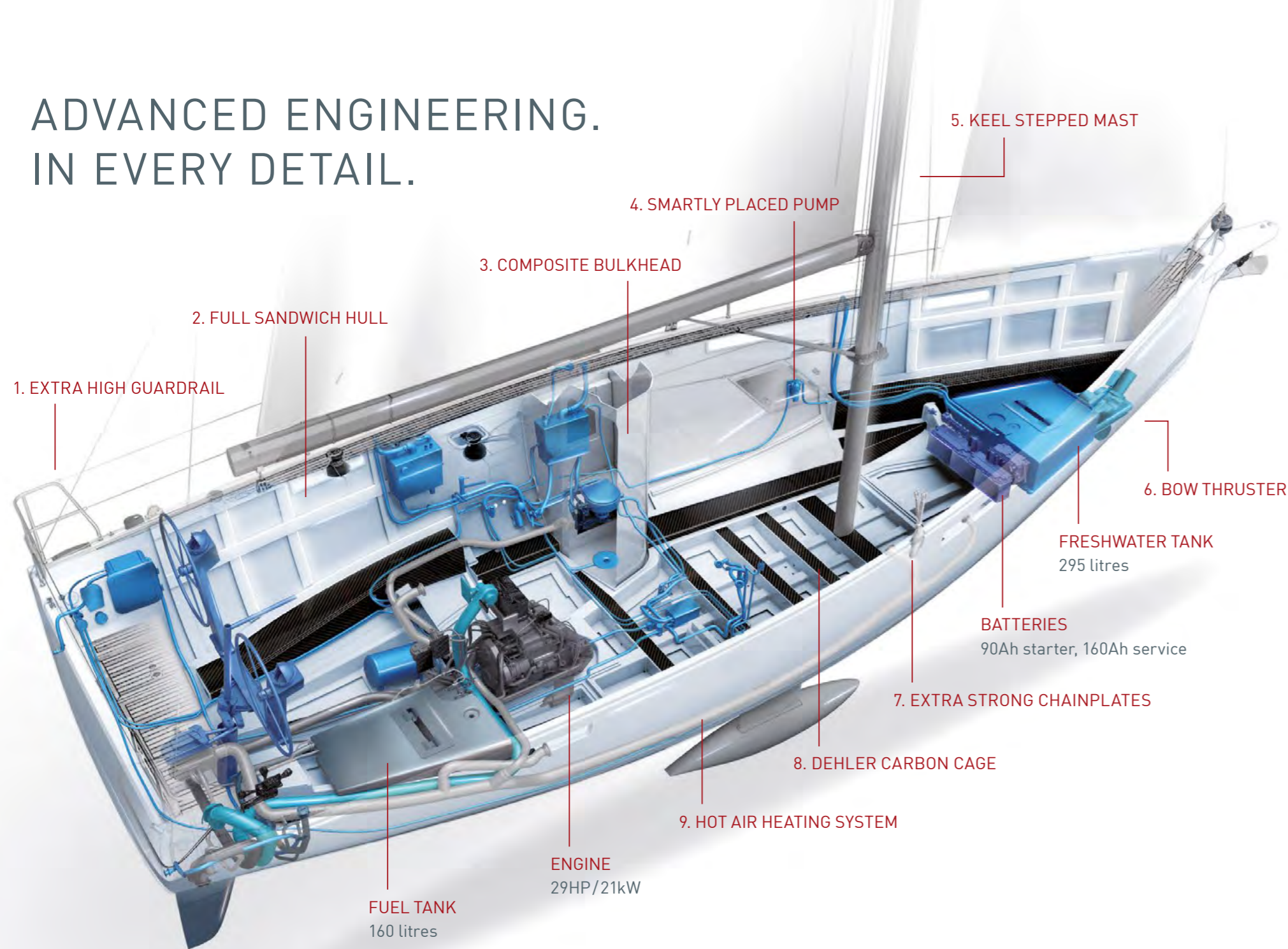

1. **EXTRA HIGH GUARDRAIL**
for maximum safety at the helm.
2. **FULL SANDWICH HULL**
Balsa wood sandwich core laminated with premium quality vinylester resin – rigid and lightweight.
3. **COMPOSITE BULKHEAD**
The shower compartment is designed as a separate bulkhead. It integrates seamlessly into the hull design and is particularly easy to clean.
4. **SMARTLY PLACED PUMP**
To reduce noise, the freshwater pump is installed outside the cabins.
5. **KEEL STEPPED MAST**
for optimal distribution of forces, more stability, better trim.
6. **BOW THRUSTER**
folds out when needed.
7. **EXTRA STRONG CHAINPLATES**
Reinforced with ten layers of glass fibre, the chainplates can withstand enormous tensile forces.
8. **DEHLER CARBON CAGE**
The floor structure is reinforced with carbon fibre at key stress points. Torsion in the hull is minimised under high rig loads and in high seas, enabling it to better withstand the forces of water and wind.
9. **HOT-AIR HEATING SYSTEM**
Diesel-operated, programmable.

KEEL TYPES

STANDARD KEEL

- | High performance deep fin keel
- | Low centre of gravity
- | Most of the weight is concentrated at the lowest point below the waterline
- | Draught 2.03m
- | Weight 2,380kg

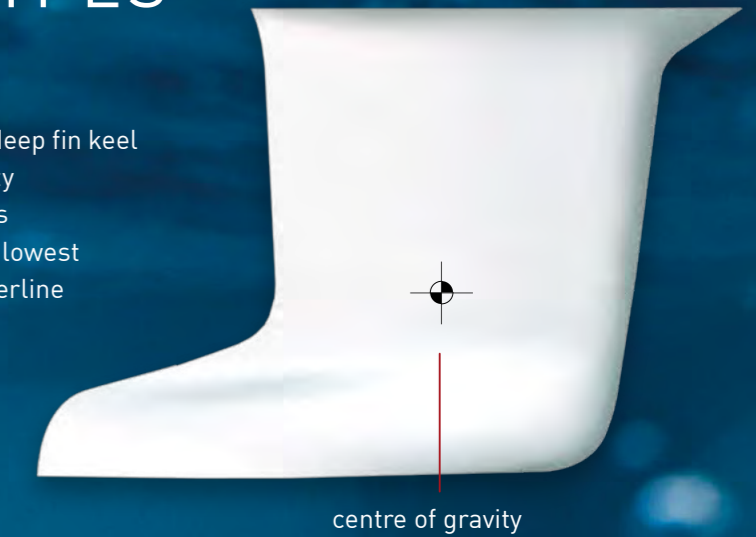

COMPETITION KEEL

- | A hybrid construction comprising a cast iron fin with a lead bulb
- | Extremely low centre of gravity, leading to highest possible righting moment
- | Narrow fin for reduced drag and higher speed
- | Bulb shape achieves optimum hydrodynamics
- | Perfect ballast distribution for optimal trim in water
- | Draught 2.24m
- | Weight 2,050kg

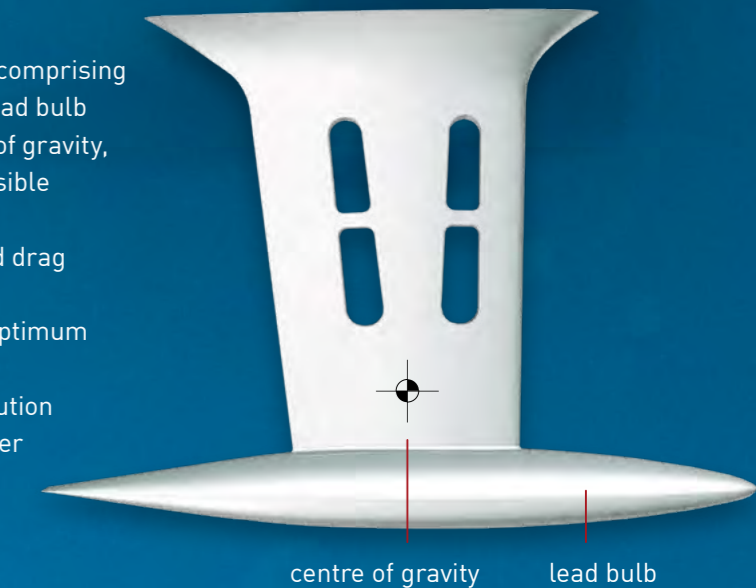

POWERFUL SAILS FOR PASSIONATE SAILORS

Fueled by the best sailors, sailmakers and designers in the world and comprehensive data and insights from every project they've worked on – from superyachts to dinghies – Quantum developed their latest high-tech products for Dehler yachts.

The result is a custom sail engineered to achieve the perfect shapes that, simply put, give you confidence through control and ease of use for the best experience on the water time and time again.

QUANTUM TP6 | HIGH-END MEMBRANE LAYERS

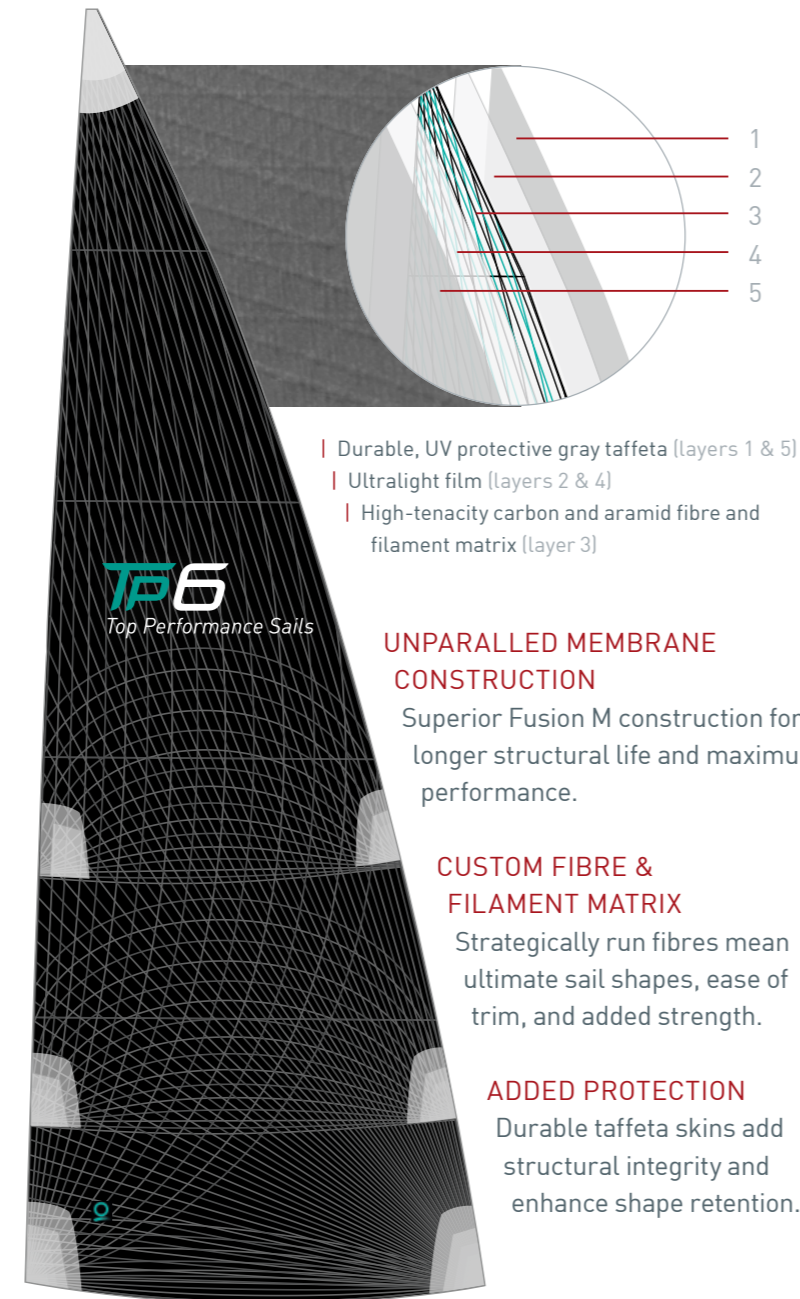

- | Durable, UV protective gray taffeta (layers 1 & 5)
- | Ultralight film (layers 2 & 4)
- | High-tenacity carbon and aramid fibre and filament matrix (layer 3)

UNPARALLELED MEMBRANE CONSTRUCTION
Superior Fusion M construction for longer structural life and maximum performance.

CUSTOM FIBRE & FILAMENT MATRIX
Strategically run fibres mean ultimate sail shapes, ease of trim, and added strength.

ADDED PROTECTION
Durable taffeta skins add structural integrity and enhance shape retention.

QUANTUM AC5 | PERFORMANCE LAYERS

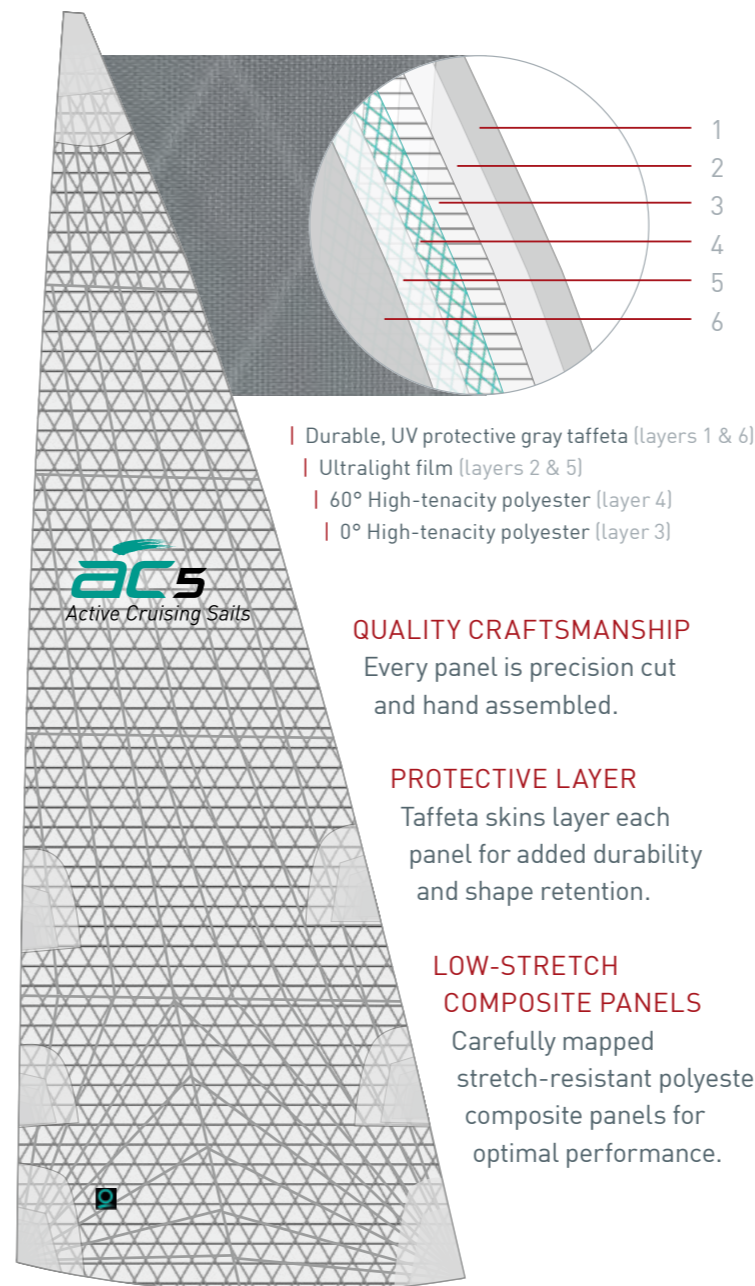

- | Durable, UV protective gray taffeta (layers 1 & 6)
- | Ultralight film (layers 2 & 5)
- | 60° High-tenacity polyester (layer 4)
- | 0° High-tenacity polyester (layer 3)

QUALITY CRAFTSMANSHIP
Every panel is precision cut and hand assembled.

PROTECTIVE LAYER
Taffeta skins layer each panel for added durability and shape retention.

LOW-STRETCH COMPOSITE PANELS
Carefully mapped stretch-resistant polyester composite panels for optimal performance.

DEHLER FREERIDE | 62.80M²

The Dehler **FREERIDE** is the perfect intermediate size between genoa and gennaker, offering the largest wind range in its class. That means, the FREERIDE speeds up your Dehler, no matter if you are sailing a close reach or broad reach course. Fully optimised for single-handed sailing, it is set out of the specially designed sailbag at deck level. Attaching it to the anchor bracket and gennaker halyard takes two simple clicks. The rolled-up sail can remain set as second forestay in the marina. It is operated with the gennaker sheets using any winch in the cockpit.

- UV-PROTECTED —
- INTEGRATED TORSION CABLE AND ENDLESS FURLING SYSTEM —

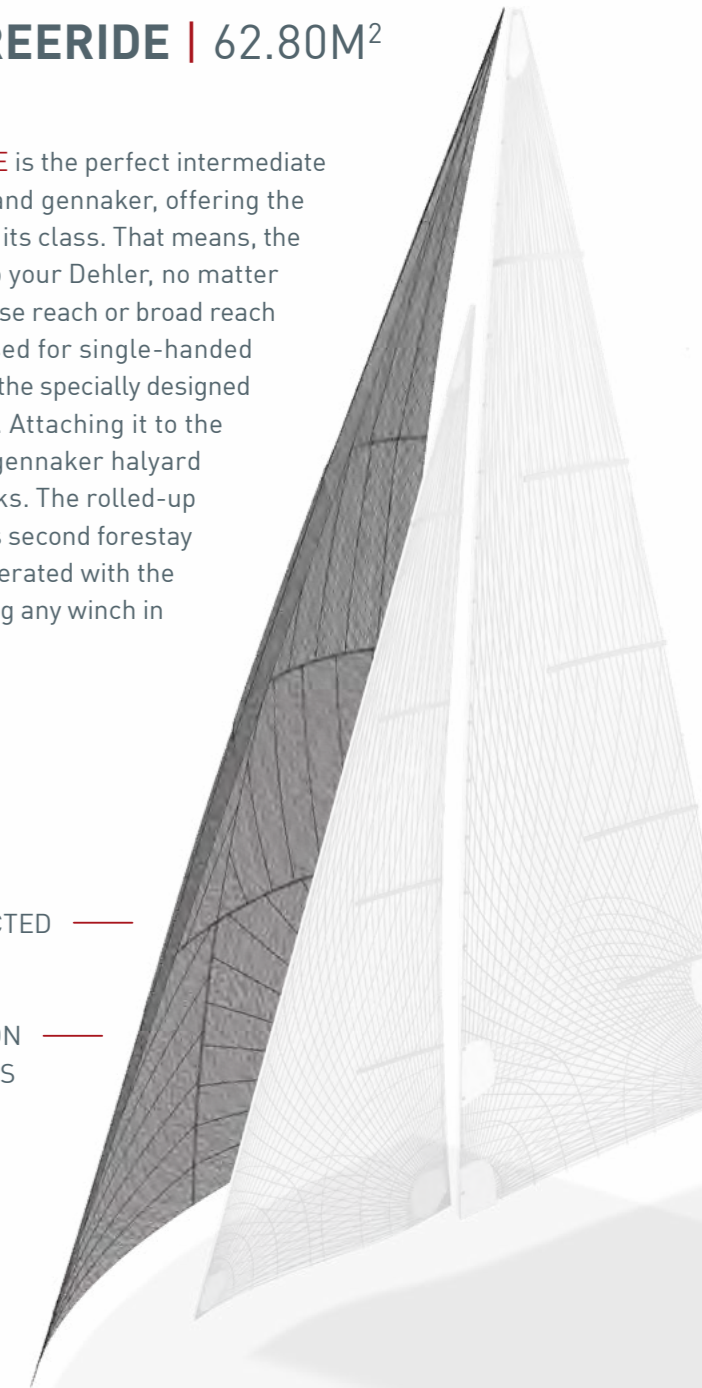



GELCOAT HULL,
WATERLINE & COVELINE



signal white RAL 9003
dark blue RAL 5004



grey RAL 7040
signal white RAL 9003



grey RAL 7040
dark blue RAL 5004

PAINTED HULL,
WATERLINE & COVELINE

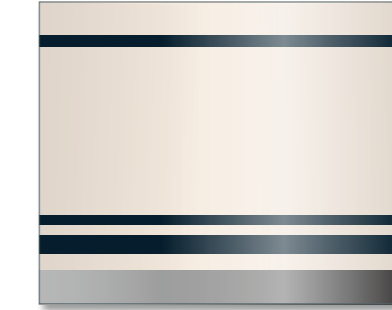

oyster white T 9128
flag blue T 5153



palma blue M 5922 (metallic)
off white T 9130



flag blue T 5153
dark grey T 7156



sunfast red T 3150
off white T 9130



EXTERIOR COLOURS AND MATERIALS

EXPRESSIVE COLOURS AT YOUR COMMAND

_ Make a style statement with your Dehler. Your dealer will be happy to show you Dehler's entire upholstery and colour collection.



EXTERIOR | COVERS & UPHOLSTERY

Top-quality fabrics defy any weather and shape the appearance of your Dehler with contemporary maritime colors.

MAINDROP, SPRAYHOOD, STEERING WHEEL COVER, COCKPIT TABLE COVER OPTIONS

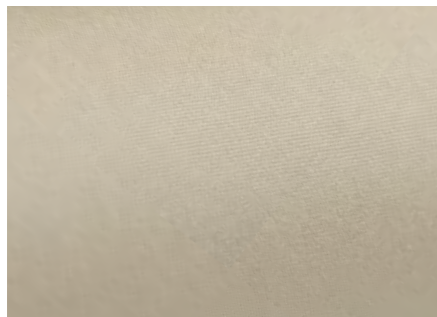

cream



light grey

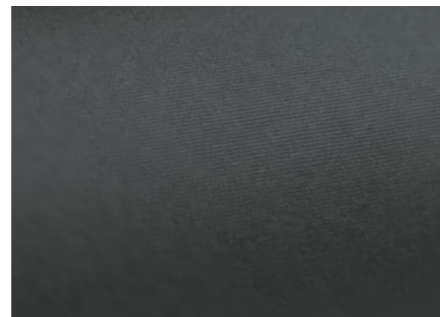

dark grey

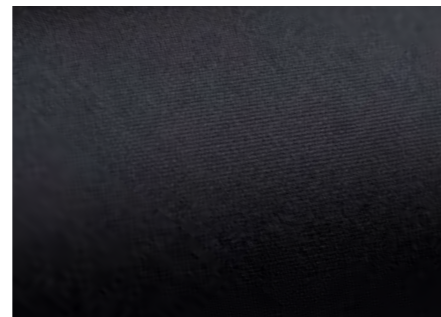

black

COCKPIT CUSHIONS OPTIONS



light grey

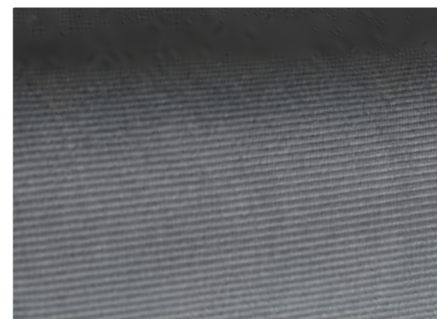

dark grey

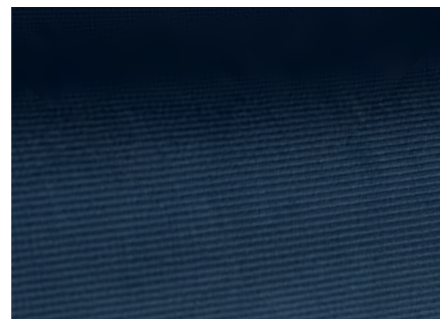

dark blue

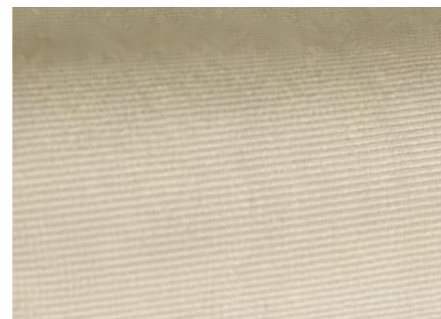

beige

EXTERIOR | NATURAL TEAK & SYNTHETIC TEAK

SYNTHETIC TEAK OPTIONS

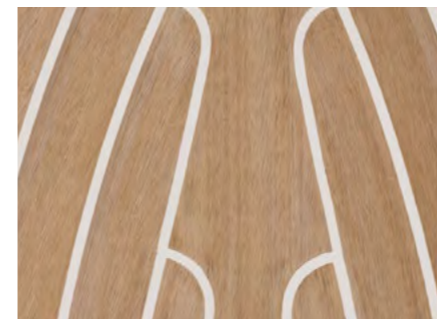

teak look | white caulking

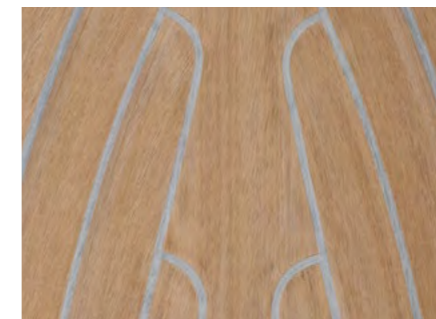

teak look | grey caulking

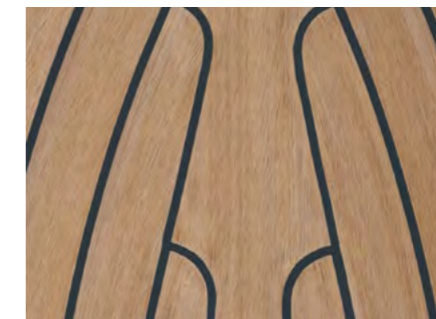

teak look | black caulking

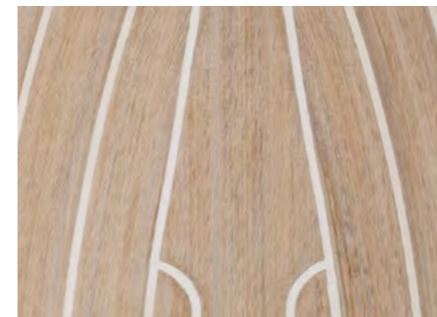

scrubbed look | white caulking



scrubbed look | grey caulking

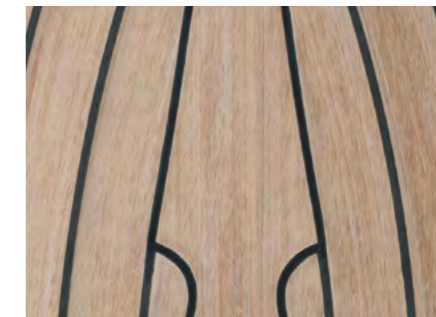

scrubbed look | black caulking

NATURAL TEAK OPTION

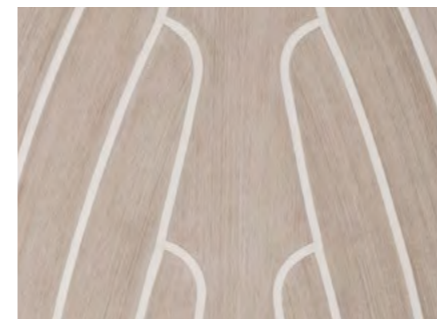

weathered look | white caulking

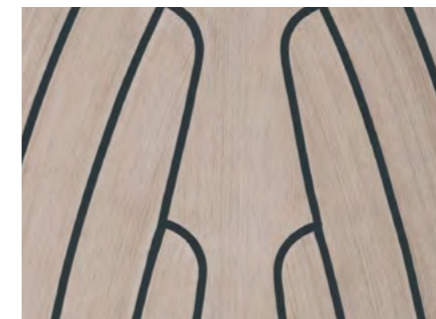

weathered look | black caulking

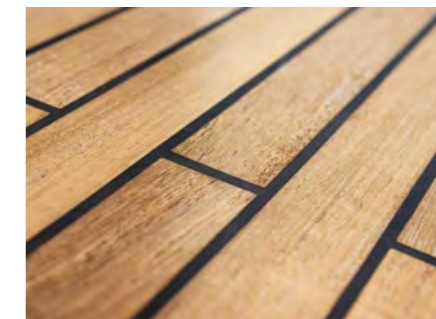

teak





INTERIOR | UPHOLSTERY

FINEST MATERIALS TO SUIT YOUR TASTE

Mix and match as you wish. All interior upholstery can be matched with the following piping colours: gold, silver, red, blue and black.

PACIFIC OPTIONS



cliffside / blue piping



oyster / black piping



muscat / silver piping



graphite / gold piping

ADRIATIC LEATHER OPTIONS



ivory / blue piping



mud / black piping



clay / red piping



basalt / gold piping

INTERIOR | UPHOLSTERY

BALTIC STANDARD



cream / gold piping

ARCTIC OPTIONS



taupe / blue piping



silver / red piping



stone / silver piping



denim / gold piping

INTERIOR | SURFACES



WORKTOP GALLEY STANDARD

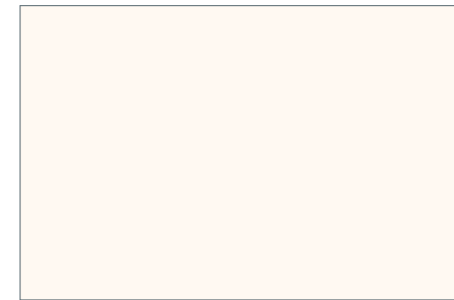

off white

OPTION



dark grey

FURNITURE WOOD STANDARD

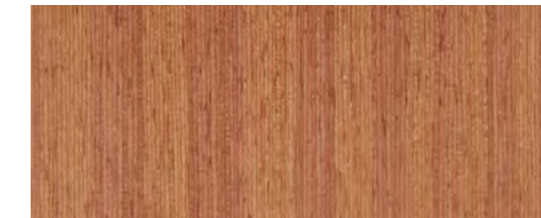

mahogany

OPTIONS



teak



oak

FLOORBOARDS STANDARD



australian acacia

OPTIONS



noce nero

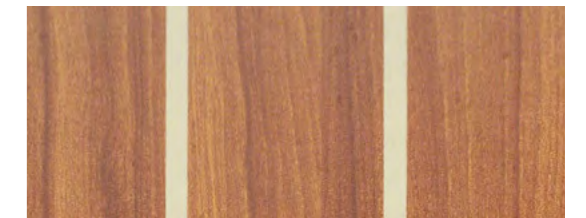

classic stripes

DEHLER CONNECT – BE SMART, BE INTELLIGENT AND UP TO DATE

MyDehler Safety Cloud

The MyDehler Safety Cloud enables real-time monitoring of your Dehler: anytime, anywhere, simply via the app. Protect your precious yacht remotely, as if you lived on board. You can organise maintenance and service with unprecedented ease. Thanks to the electronic logbook, a smartphone is all you need to share your sailing experiences with others. In short: this system will add a whole new dimension to your sailing passion.*

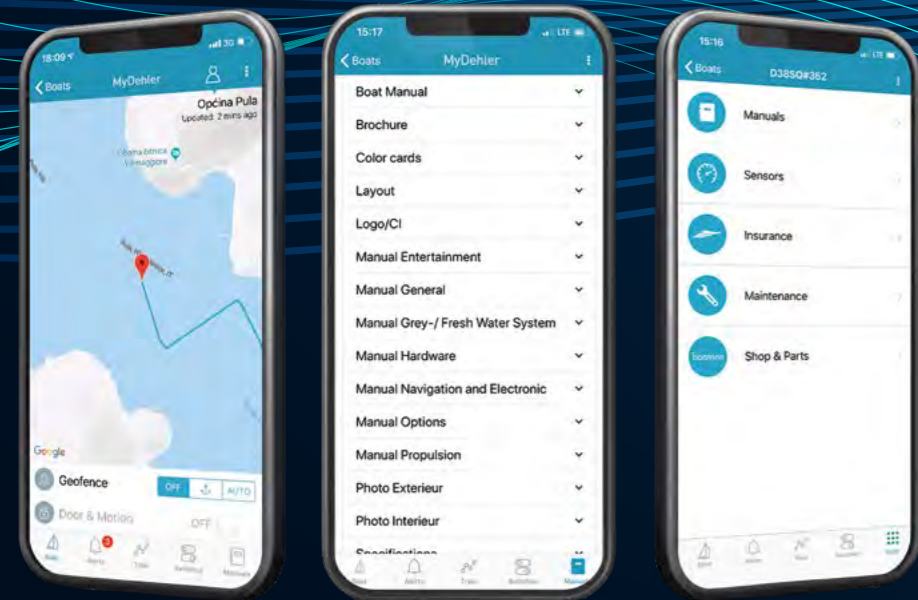

Sensors
Real-time monitoring of battery levels and devices.



Maintenance
Push notifications before due dates for maintenance of all components.



Switch Control
Control of lighting and electrical devices (optional).



Shop & Parts
Feature for ordering equipment, supplies and spare parts.



Alerts
Notifications for battery, bilge, shore power, anchor, geo fencing and more.



Manuals and operating instructions
for all units and components on board.



Trips
Electronic logbook with archive and share function for social media platforms.



Insurance
Exclusive in-app offers and conclusion of all insurances around the boat by Pantaenius.



Report Issue
Direct contact to the dealer.

MyDehler Sound Theatre

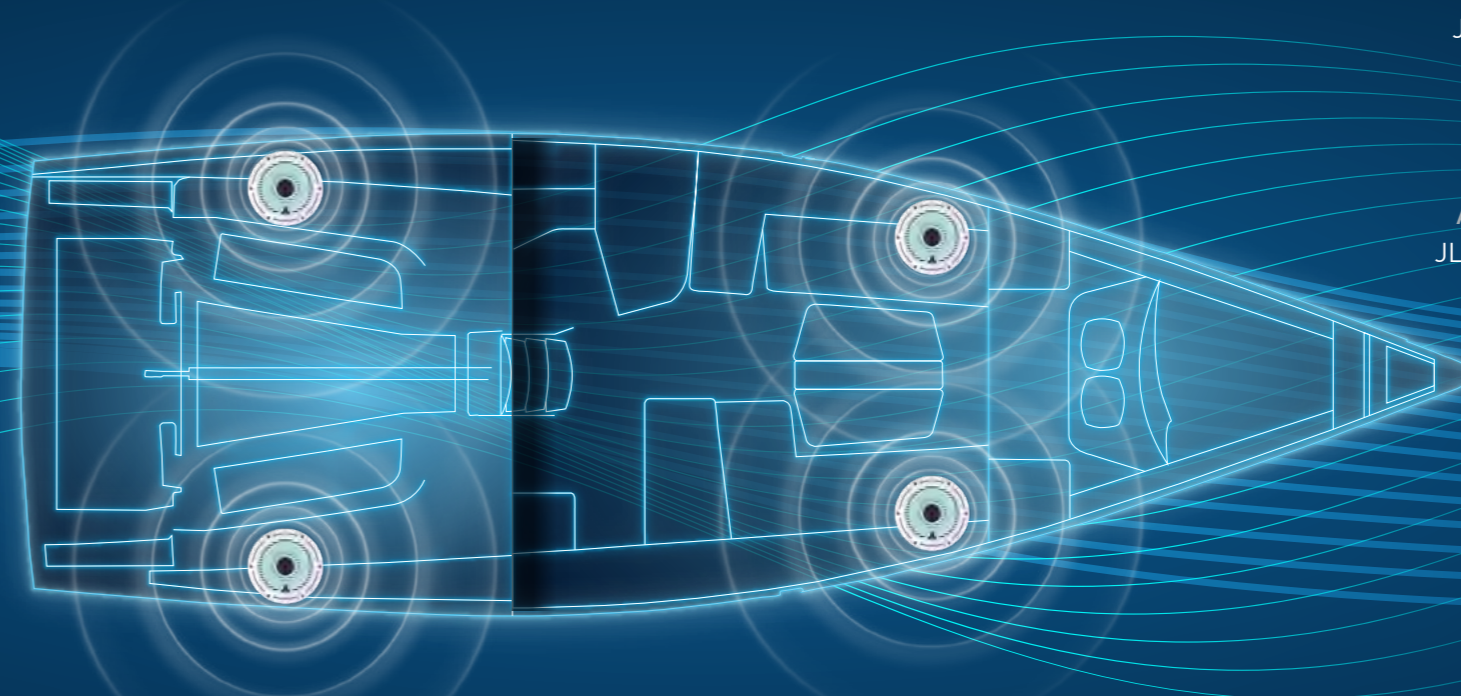

High-end sound meets high-class living
Your first impression: brilliance. Even the finest acoustic nuances are brought out. Two pairs of loudspeakers – one in the cockpit, one in the saloon – overwhelm your ears with their outstanding clarity. Simplicity is the second thing you'll notice. We've brought the design and operation of the system back to the essentials, for intuitive control via the chart plotter or the separate control head. And thirdly, you'll enjoy the thrill of cutting-edge technology. The system is wireless, very compact and almost limitlessly flexible. This is the connectivity of the future.

JL Entertainment Package:

Remote
JL Audio MMR-40



Audio Head Unit
JL Audio MM 50 BE
with bluetooth



Control via
B&G Zeus³ 7"
chartplotter



Speakers
2 x 2 JL Audio
speakers



REFINE YOUR DEHLER WITH THE BEST

_ Top quality equipment packages for your Dehler 385Q. You will find full details of each component in the price list. Or contact your Dehler dealer.



CRUISING

CRUISING PACKAGE

- | Teak on coach roof, cockpit bottom and bathing platform
- | Bathing platform, manual fold-out with swimming ladder
- | 2 additional cleats, midship, retractable (1 each side)
- | Anchor windlass, electrical with automatic fuse, remote control with chain counter
- | Delta-anchor 16kg, galvanised with 30m galvanised chain
- | 2 vents for coach roof hatches
- | MyDehler Safety Cloud with 24 months subscription and device installed on board
- | Battery set, capacity: 1x 90Ah + 2x 160Ah AGM
- | Blind set with flyscreens for hatches
- | Blinds for hull windows and side coach roof windows
- | Wind indicator
- | Flagpole
- | 6 fenders, 4 mooring lines, plaited
- | Dehler maintenance kit

UPGRADE | FLEXITEEK (colour selection)

- | Flexiteek on coach roof, cockpit bottom, cockpit benches and bathing platform

UPGRADE | STAINLESS STEEL ANCHOR WITH CHAIN

- | Delta-anchor 16kg, stainless steel, with 'Power Ball' swivel and 50m stainless steel chain
- | Upgrade – Battery set Lithium-ion
- | Battery set, capacity: 1x 90Ah + 3x 105Ah Li-ion batteries



COMPETITION

COMPETITION PACKAGE

- | Cove line – Competition
- | Rudder – Competition
- | 2 LEWMAR 45 Race Plus manual halyard winches
- | 2 LEWMAR 50 Race Plus manual secondary winches
- | 2 LEWMAR 50 Race Plus manual mainsheet winches
- | Genoa tracks (Competition), ball bearing sliders, adjustable from cockpit
- | Jib barber hauler with low-friction ring
- | Spinlock removable throttle

UPGRADE | ELECTRIC HALYARD WINCH

- | 2 LEWMAR 45 Race halyard winches, port: manual – stb: electric with automatic fuse

UPGRADE | COMPETITION KEEL

- | T-keel, cast iron/lead, (Competition) draught: 2.24m



NAVIGATION

B&G NAVIGATION PACKAGE | CRUISING

- | Instrument pod on helm station stb
- | 2 B&G Triton² multifunction displays, 1 per helm station, incl. transducer (wind/depth/speed/temperature)
- | B&G VHF V60 at chart table, incl. wireless remote handset H60
- | B&G Zeus³ 7" chartplotter, stb helm station
- | B&G Autopilot with Triton² control unit and Precision 9 compass
- | VHF preparation with antenna and splitter for FM and AIS

UPGRADE | COMPETITION

- | 2 B&G H5000 multifunction displays, 1 per helm station, incl. transducer (depth/speed/temperature) and wind sensor at vertical carbon mast head unit
- | B&G Autopilot with H5000 control unit and Precision 9 compass
- | B&G CPU Hydra computer (only with B&G H5000 instrument)

UPGRADE | SECOND CHARTPLOTTER

- | Instrument pod on helm station ps
- | B&G Zeus³ 7" chartplotter, ps helm station



GENNAKER

GENNAKER PACKAGE

- | QUANTUM Gennaker (colour selection)
- | Squeezer for Gennaker
- | Gennaker/Freeride package incl. halyard, 2 sheets, 2 blocks and padeyes

UPGRADE | COMPETITION GENNAKER

- | Competition composite bowsprit with integrated anchor fitting
- | QUANTUM Competition Gennaker (colour selection)



ENTERTAINMENT

JL ENTERTAINMENT PACKAGE

- | JL Audio MediaMaster 50 with bluetooth – for saloon and cockpit
- | 2x 2 JL Audio speakers in saloon and cockpit
- | JL Audio MMR-40 remote control



25936 YACHTS

have been delivered by Dehler since 1963 –
an experience that results in excellence.

932 INNOVATIONS

that made sailing and living on board significantly
more enjoyable were invented by Dehler.

65 MODELS

in all sizes up to 60 feet were created
by our designers and developers.

58 YEARS

of yacht building have continuously increased
the demands we place on ourselves and made us
one of the leading sailing boat manufacturers.

1 PROMISE

follows from all that we've achieved so far:
To build our next Dehler 38SQ exactly as you desire it.

#dehleryachts

Dehler **38 SQ**

Dehler Yachts UK

Chandlery Building, Hamble Point Marina,
Hamble, Southampton SO31 4NB

www.dehler.co.uk

Design: www.smz.de | Print: Eggers Druckerei & Verlag GmbH |
Photos: Nico Krauss, HanseYachts AG. This brochure is not contractual.
The yachts depicted partly comprise special equipment not
included in the standard scope of supply. Illustrations may not
correspond with current versions. Subject to alterations in design and
equipment without notice and errors excepted.

©2021 Dehler | CIBD38SQ/A/0321